



SOLO 103

The Solo 103 miniature full-range speaker



Concept

I had had these Fostex FE103 drivers in my cupboard for years just waiting for a suitable project. I was working on a different set of speakers that were made of birch multiplex and, you guessed right, there were some leftover pieces of wood. Just enough to make a small pair of cabinets with. I didn't want to build a large time consuming TQWT or horn-loaded cabinet seeing as this was also going to be an in-between-project. I decided to make a symmetrical loaded reflex cabinet (a bit like an Onken cabinet) because using a single full-range driver means point source that should also apply to the reflex ports. A reasonable amount of lower midrange energy would also be radiated from the ports so I didn't want to mess up the symmetrical radiation pattern.

The driver

The [Fostex FE103](#) (a.k.a. ACR FE103). A not very expensive 100mm (4 in) non-coated paper cone type full range driver. It uses a simple stamped steel chassis holding a lightweight short voice coil moving assembly. The moving mass is only 2,7 grams! Frequency response is up to 18kHz, which is high enough for a single driver speaker. Sensitivity is rated at 89dB at 1W/1m. Continuous power rating is only 5 watts but you will be surprised how loud 5 watts can be. Resonance frequency f_s is 80Hz and X_{max} is only 0,35mm so don't expect thunderous deep bass and high SPL's from these little chaps.



That's a nice pair!

Cabinet construction

Humble Homemade Hifi SOLO-103

- * 18mm berken multiplex, blank gelakt zijde glans
- * breedbanddriver: Fostex FE103 - Vbox=4,9 liter netto fb=82Hz f3=85Hz

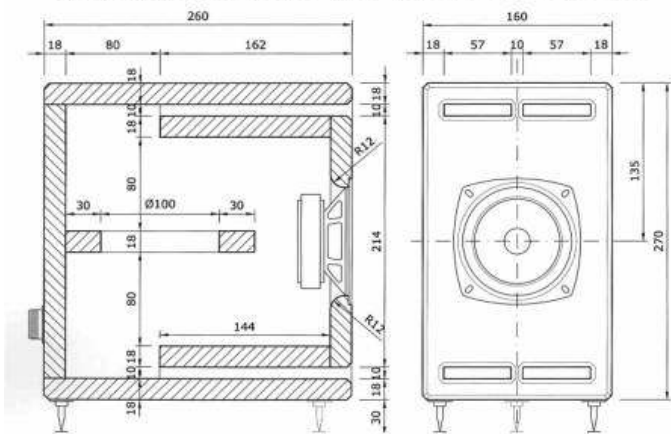

The original plans differ slightly from the final product.

Here pictures say more than a thousand words. All panels are made of 18mm Finnish birch multiplex completed on the outside with a clear water based varnish. A nice coincidence is that the varnished cabinets have the same colour as the cones of the Fostex drivers. All outside edges are routed with a 6mm angle. To give extra strength to the top and bottom panels, small 10x10mm wooden strips were glued between the top and bottom panels and the two reflex port panels. This divides the two ports up into six little vents tuned to 82Hz giving a -3dB point of about 85Hz. Furthermore there are three extra braces in the rear section of the cabinet of which the centre one also supports the rear panel. To make the cabinet as heavy as possible and cut down unwanted panel resonance's I glued 10mm thick rubber sheets to all of the inside walls except for the baffle and ports. The two braces are also kept free so that the airflow is not obstructed. The rubber sheets were then covered with high pile carpet (like the jazzy pattern, don't you?!). The only other piece of damping material is a piece of BAF of 15x30cm rolled up and placed directly behind the driver in the centre of the enclosure. On the rear of the cabinet I used a pair of standard binding posts. The cabinet has three spikes underneath that rest on a custom made stand. The T-shaped stand is similar in design to that of the Proteus and is built from 3 layers of 18mm mdf of which the middle layer is hollow and filled with dry sand. The stands have three little metal feet to give optimum contact to the floor.



The cabinet and the damping material.

The crossover network

This is one of those things you just have to design by ear. No computer simulations here. I had tried simulating it with the help of software but what measured good and what sounded good were two different worlds. All that is used here is a simple notch filter to lower the midrange output level to match the bass and treble better. Even though the drivers used are rather cheap I would advise to use the best filter components you can get (there are only three per speaker so I won't cost that much). The inductor must have an air-core for no saturation and low distortion. The lower Rdc the better, it improves bass response. It is amazing how sensitive the capacitor is, using a standard Audyn Cap MKP or similar is a waste! A good price/quality ratio is achieved with a LeClanché or Solen Fast Cap. When a high-end Audyn Cap Plus, Mundorf Supreme Cap or Hovland Musicap is used the amount of extra clarity and detailing is unbelievable. I used a metal oxide resistor, here again personal taste will determine what is needed, standard cemented resistors are out of the question.

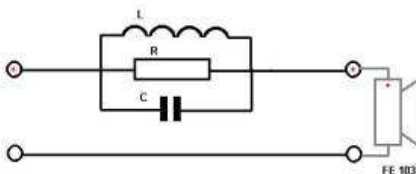

Filter components:

L = 0,82 mH air-core inductor 2,00 mm wire, R = 0,15 ohms

C = 4,7uF MKP foil capacitor - Audyn Cap Plus, Mundorf Supreme Cap or similar

R = 10 ohms / 10 watts metal film resistor

Listening impressions and remarks

I have a love and hate relationship with these speakers. When playing an intimate jazz trio, a Beethoven string quartet or solo vocals you nearly fall off your chair with amazement. Such openness, neutrality and an amazing sound stage with immense depth and width. Every thing can be pin-pointed in the virtual soundscape, every little sound, the turning of a page of sheet music, the breathing of the instrumentalists, its all there. But as soon as it gets a bit heavy (large orchestral works or complex jazz-rock) everything gets muddled up. Here the shortcomings of small cone area, minute Xmax and a single cone trying to produce bass and treble at the same time show. What it also misses is (deep) bass – the addition of a small sub-woofer could help a lot here. When they have support from a rear wall the lower end becomes more in balance with the rest. Of course you can't expect ultra low bass orgies but the music does have enough body to it. Okay, it doesn't have the extreme top-end clarity of a good tweeter or the deep bass of a nice large woofer but if you can live with that you will be amazed! For intimate proximity listening of small combo's, you can't get much better than this considering how cheap the speaker is.



The finished products on their sand-filled stands.

NOTE: This design is strictly for the home DIY enthusiast and not to be used professionally without my permission!

Tony Gee, The Netherlands

January 2003