



# Soup Sandwich

## Soup Sandwich – An alternative meal to the Soup Ceramique

Loudspeaker designing is like cooking. From several different ingredients you hope to create a culinary masterpiece. The art is in choosing the correct ingredients and blending them together in a way that you find pleasing. Give ten different people the same ingredients and you will get ten different recipes. Here is my attempt at creating a musical masterpiece. This version is designed to give maximum pleasure for a smaller investment than the original Soup Ceramique. The woofer is less expensive and the crossover uses far less components. These speakers have an extremely high price/quality ratio!



### The tweeter

The [Thiel & Partner C2-12/6](#) is a Ferro-fluid filled tweeter with a 25 mm lightweight concave ceramic dome. Designed for 3-way systems or small, low-output 2-way designs. Very high resolution and very good dispersion up to 42 kHz. Low resonance frequency allows first order filtering and a crossover frequency as low as 2 kHz. The ultra hard ceramic dome material moves like a piston well above the audible frequency band and the high internal sound velocity features very low distortion and virtually no coloration.

### The midrange

The [Thiel & Partner C2-79/6](#) is a true midrange driver with 90 mm light weight concave ceramic dome and ferrofluid damping. Recommended as midrange for high quality 3- or 4-way systems. Very high resolution and very good dispersion up to 5 kHz. Low resonance frequency allows first order filtering from 200 to 4000 Hz. The ultra hard ceramic dome material moves like a piston well above the audible frequency band and the high internal sound velocity features very low distortion and virtually no coloration.

### The woofer

The [Eton 8-472/32 LH](#) is a 8" HEXACONE-woofer with longthrow technology and a heatpipe.



### The cabinet inside and out

The raw cabinets are made of thick 30mm mdf; the front baffle is double layer with 60mm total thickness. To create the angled baffle the four corners were machined to fit separate panels, if you don't have the possibility to do this, the same visual effect can be done by making the four corners even thicker on the inside and then cut the angles away as can be seen during my factory tour. The veneered cabinets were coated with 6 layers of clear water based, polyurethane reinforced varnish. Then a final layer of bee's wax polished to a nice deep but not too glossy shine. Internally there are several bradings to give extra stability to the cabinet, the separate midrange enclosure also adds to this extra strength. All internal walls (including the midrange enclosure) are covered with a double layer of bitumen (2x4mm) to add extra mass and control panel vibrations. A 10mm layer of felt covers the inside of the woofer compartment to minimize internal reflections. The midrange enclosure is filled completely with sheep's wool. The bass volume is tuned to taste with bonded acetate fibre (BAF) lightly filling the whole enclosure.

The 30mm thick black painted base-plate acts as a visual plinth to give the speaker a more graceful appearance and also works as a rear vent for the down-firing reflex port. The Soup Sandwich is a ported design rather than a sealed enclosure. The down-firing port is located on the cabinet bottom next to the input terminals. A single pair of input terminals is provided on the enclosure bottom. This means that the Soup Sandwich cannot be bi-wired, and that the loudspeaker must be tipped on its side to connect loudspeaker cables. Three cones are used - two for the rear and one for the front of each loudspeaker. The cabinet features a faceted front baffle; a shape that further reduces diffraction, allows for a thicker baffle, and contributes to wider dispersion. The entire faceted structure is a solid block made from two layers of mdf. The resulting structure keeps the cabinet weight reasonable. The cabinet's swept-back profile better time-aligns the drivers, and makes the speaker more stable by shifting the massive front baffle's centre of gravity rearward.



The cabinet measures 1025x260x405mm with an internal volume of about 50 litres for the woofer tuned to about 33Hz it gives a -3dB point around 33Hz. The port on the drawing shows the dimensions for the Soup Ceramique. The port for the Soup Sandwich is shortened to 140mm length. The closed midrange compartment is about 4 litres in volume. Depending on the positioning of the speakers in the room and personal taste this fibre can be rolled up densely or loosely to give a tighter and dryer or a fuller and warmer sounding bass. All internal wiring is silver-plated copper in PTFE.

### Crossover and listening

This crossover is simplicity itself. A three-way first-order series crossover, the only extra components being a few resistors to adjust the tweeter and midrange levels and a Zobel-network parallel to the woofer - thats all! The midrange driver is connected in reverse polarity. The end result can be described as an image with a complete "one-ness" standing on a firm foundation. The soundstage is large in all directions, especially well layered from front to back and left to right. All details are nicely highlighted. This loudspeaker has a unique ability to reach deep down to the core of musical expression in a way that makes music listening a deeper and more gratifying experience. The sound has a coherence, clarity and resolution that are exceptional! The overall balance is slightly mid-range focussed which works very nicely with jazz-trio's and classical ensembles. Happy eating!

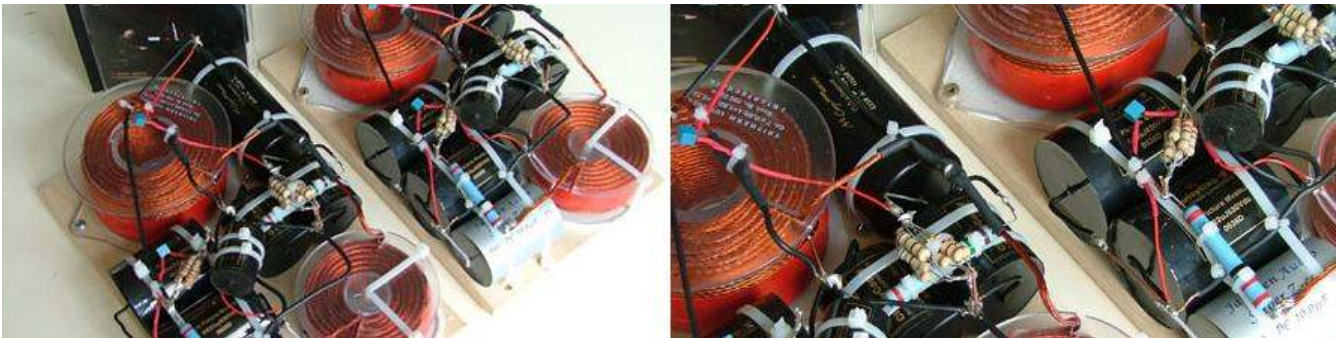

### Crossover components 2008 version

L1 = 0,68 mH Intertechnik Tritec inductor 3,5 mm wire, R = 0,11 ohms. Low Rdc and high mechanical stability are very important!

L2 = 1,80 mH Intertechnik Tritec inductor 3,5 mm wire, R = 0,21 ohms. Low Rdc and high mechanical stability are very important!

C1 = 10uF Mundorf Supreme Silver/Gold/Oil or Duelund VSF copper-foil capacitor bypassed with a 0,01uF Vishay MKP1837

C2 = 10uF Clarity Cap SA polypropylene foil capacitor bypassed with a 0,01uF Vishay MKP1837 polypropylene foil capacitor

C3 = 3x 22uF Clarity Cap SA (minimum quality) or better

R1 = 2,2 ohms - 10 watts Duelund Silver Graphite resistor

R2 = 1,5 ohms - 10 watts MOX

R3 = 3,9 ohms - 10 watts MOX

R4 = 22 ohms - 10 watts MOX

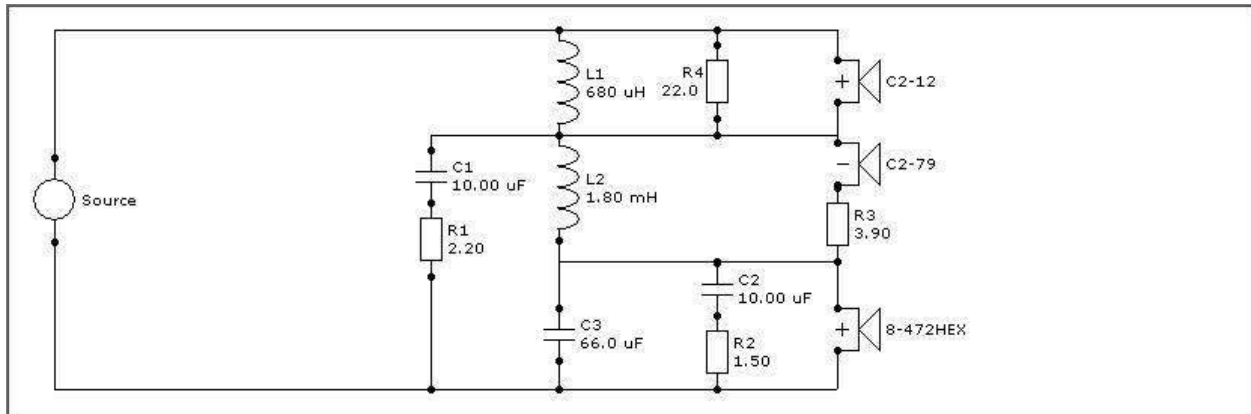

## Measurements

No problems here! A very smooth frequency curve (horizontal division 5dB's) with an efficiency of about 88dB. Due to the first order crossover, the drivers have relatively large overlaps. The impedance curve also gives no reason for concern. Average about 7 ohms with a dip around 200-250Hz of just under 5 ohms (horizontal division 4 ohms). Overall very smooth, so an easy load for most amplifiers, except for the twin peaks caused by the basreflex alignment. Tuning frequency 33Hz.

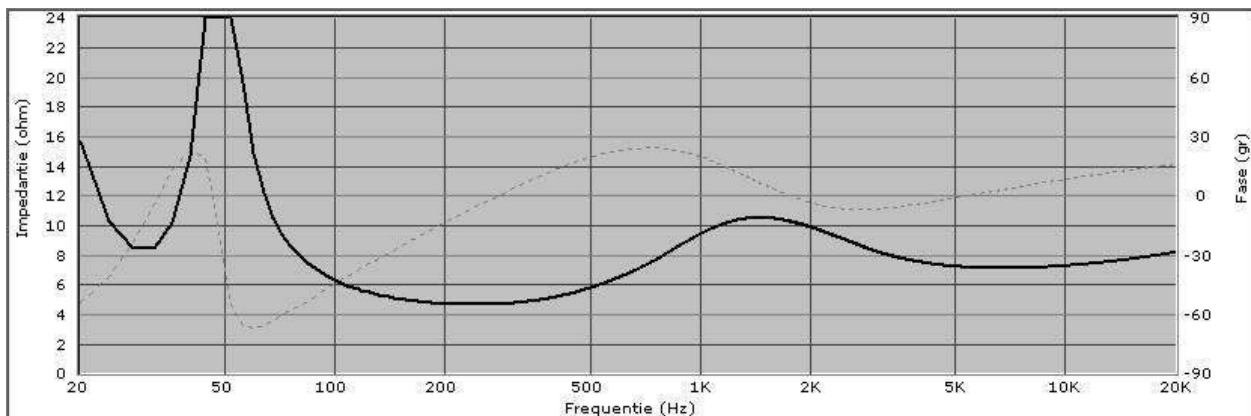
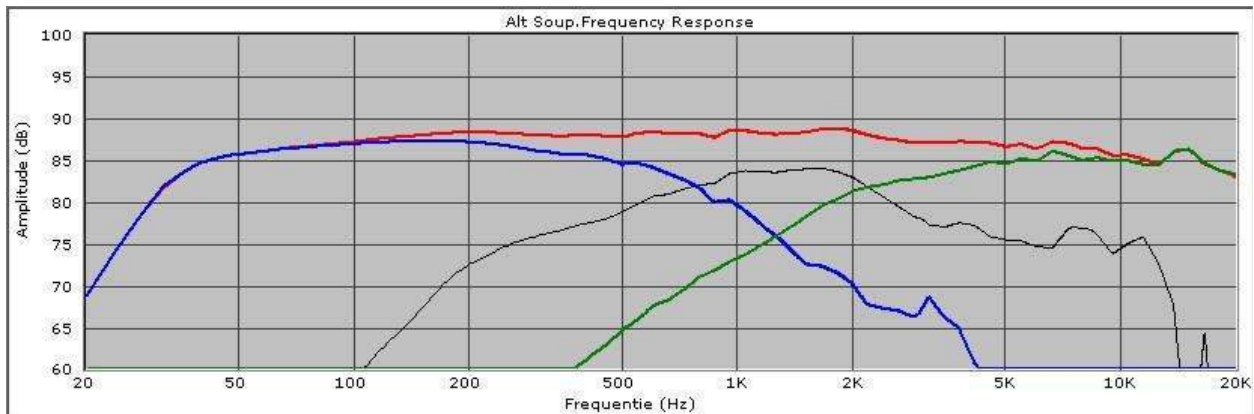

## Crossover components 2010 version

L1 = 0,68 mH CFC-12 copper-foil inductor R = 0,15 ohms

L2 = 1,80 mH CFC-12 copper-foil inductor R = 0,25 ohms

Lz1 = 0,47mH / 0,70mm wire air-core inductor R = 0,57 ohms

C1 = 4,7uF Mundorf Supreme Silver/Gold/Oil or Duelund VSF copper-foil capacitor bypassed with a 0,01uF Vishay MKP1837

C2 = 10uF Mundorf M-Cap 250VDC capacitor bypassed with a 0,01uF Vishay MKP1837 polypropylene foil capacitor

C3 = 3x 22uF Mundorf Supreme capacitor

Cz1 = 22uF Clarity Cap APW or similar

R1 = 1,2 ohms - 10 watts Duelund Silver Graphite resistor

R2 = 5,0 ohms - 20 watts MOX (2x 10 ohms / 10 watts MOX parallel)

R3a = 22 ohms - 10 watts MOX

R3b = 10 ohms - 10 watts MOX<

Rz1 = 10,8 ohms - 20 watts MOX (18 ohms + 27 ohms / 10 watts MOX parallel)

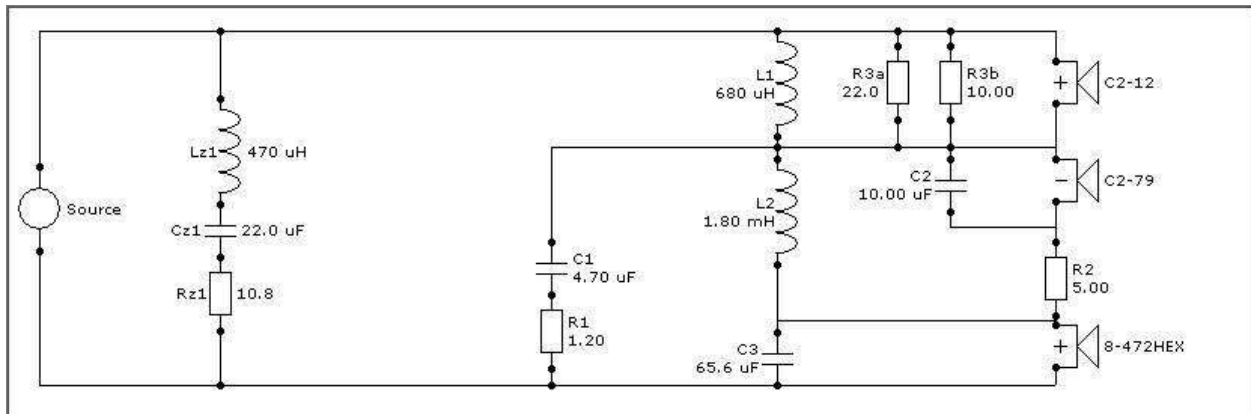

### Measurements and sound.

Compared to the 2008 crossover, the overall balance is even smoother. The midrange driver has more attenuation above 5kHz and the tweeter starts more gradually. The impedance curve is a neraly constant 5 to 6 ohms, so an easy load for most amplifiers. Tuning frequency 33Hz. The audible result is a more dynamic and clear sound compared to the 2008 version. Which version you prefer is a matter of taste and equipment match. Seeing as the main differences in components is only the values of some resistor it would be very easy to try both crossovers and see which you like best. For example you could start with 4,7uF for C1 and if you want to try the 2008 crossover, just add another 4,7uF parallel.

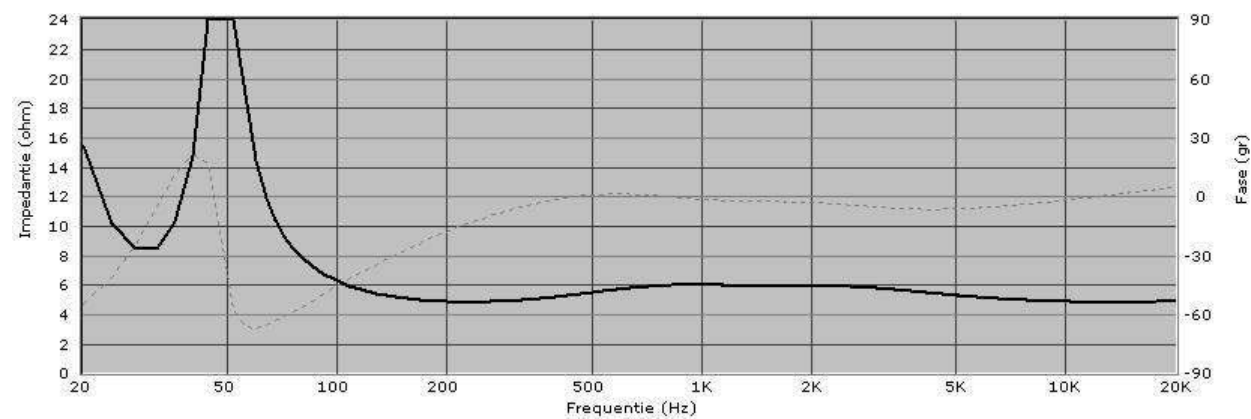
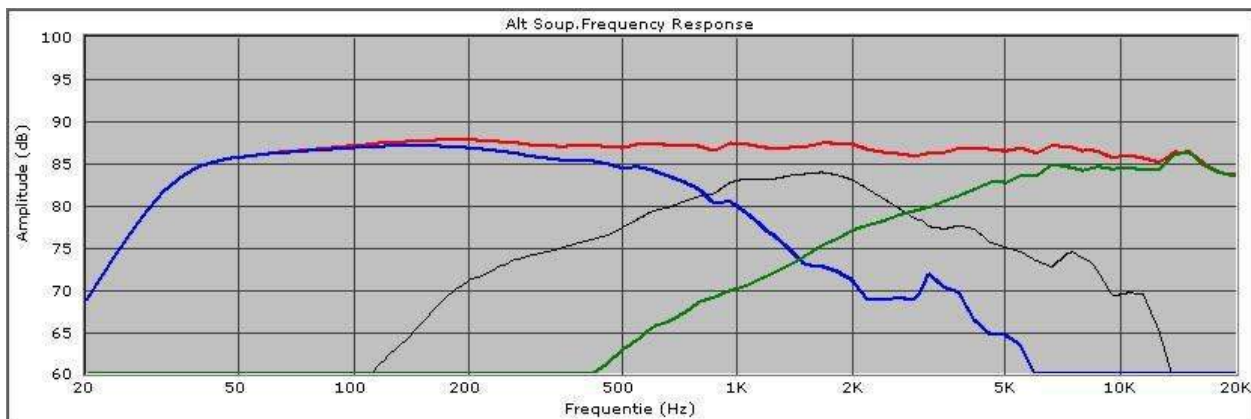

Tony Gee, The Netherlands, January 2005, updated March 2008, April 2010

>No part of this website may be reproduced in any form without written or email consent from the author. These designs are free for non-commercial use. Copyright © Tony Gee 2010